

PZE3

PROPORTIONAL 3-WAY PRESSURE REDUCING VALVE, PILOT OPERATED SERIES 10



SUBPLATE MOUNTING ISO 4401-03

p max 350 bar
Q max 50 l/min

MOUNTING SURFACE

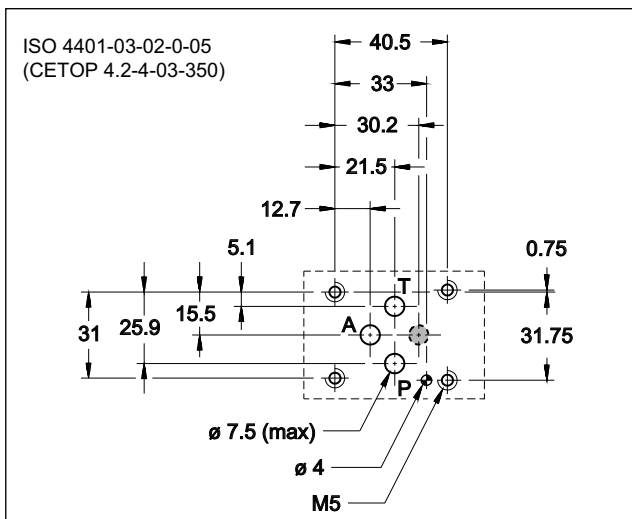

OPERATING PRINCIPLE

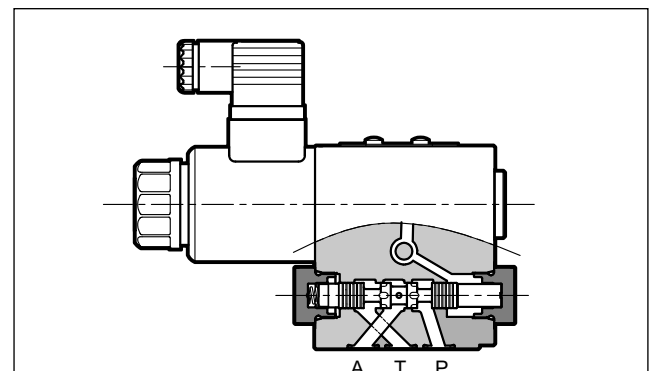

- The PZE3 valve is a proportional 3-way pressure reducing valve, pilot operated with mounting surface according to ISO 4401-03 standards.
- Its main function is to control continuously the outlet pressure on A reducing the inlet pressure P. However, the valve also prevent outlet pressure exceeding its regulated pressure value discharging in T the exceeding flow (a typical case of hydraulic counterweight or load balancing).

PERFORMANCES

(obtained with mineral oil with viscosity of 36 cSt at 50°C and p = 140 bar)

Maximum operating pressure: - P port - T port	bar	350 2
Pilot / drain flow Maximum flow (see p max = f(Q) diagram)	l/min	2 50
Step response	see paragraph 5	
Hysteresis	% of p nom	< 5%
Repeatability	% of p nom	< ±2%
Electrical characteristic	see paragraph 2	
Ambient temperature range	°C	-20 / +60
Fluid temperature range	°C	-20 / +80
Fluid viscosity range	cSt	10 ÷ 400
Fluid contamination degree	According to ISO 4406:1999 class 18/16/13	
Recommended viscosity	cSt	25
Mass	kg	2,2

- The pressure is modulated continuously in proportion to the current supplied to the solenoid.

- They can be controlled directly by an amplifier or a proper electronic control unit (par. 12)

HYDRAULIC SYMBOL

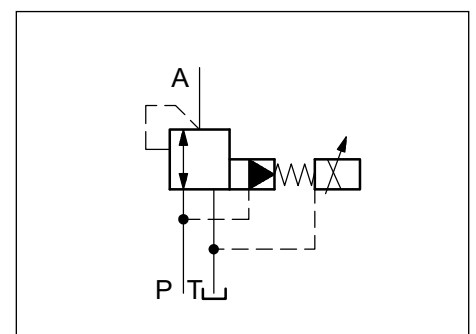

1 - IDENTIFICATION CODE

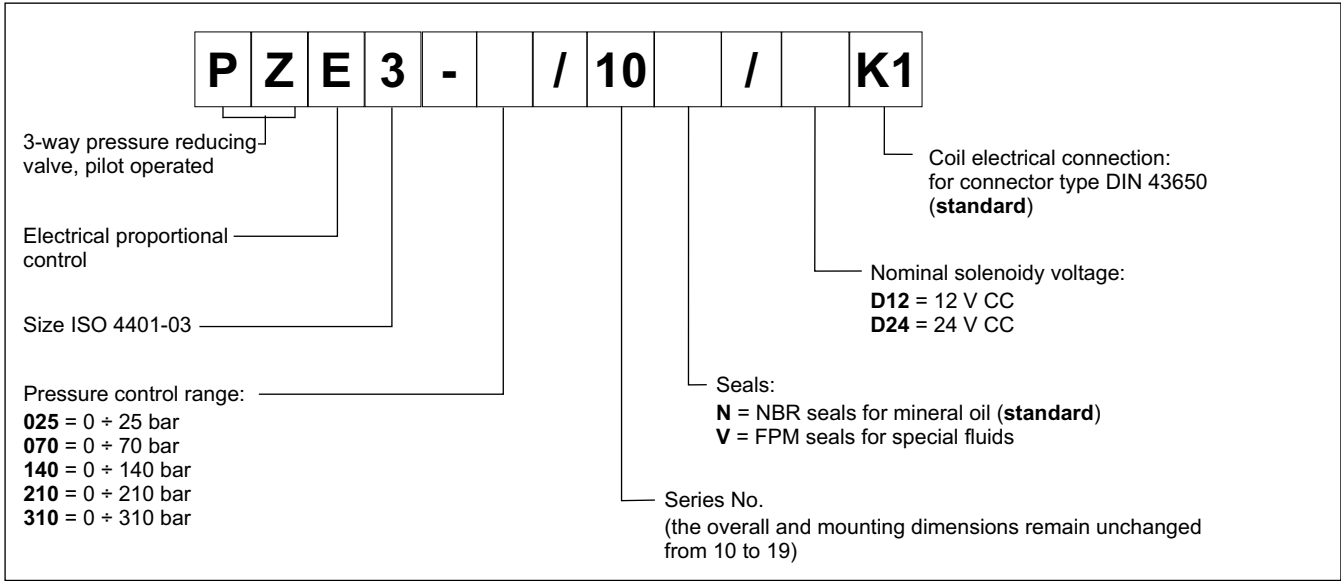

2 - CHARACTERISTIC CURVES

(measured with viscosity of 36 cSt at 50°C)

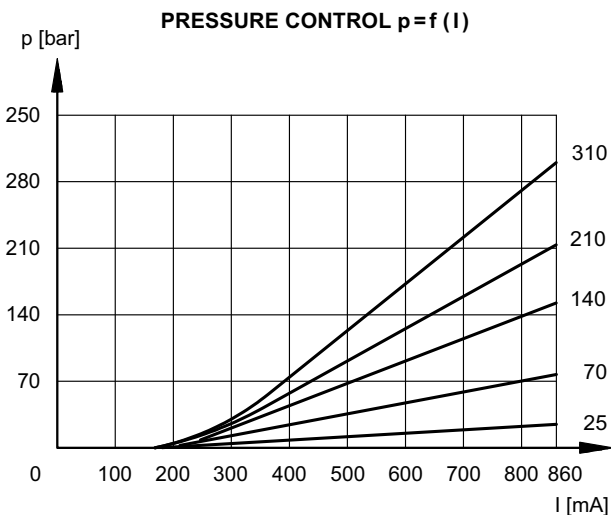
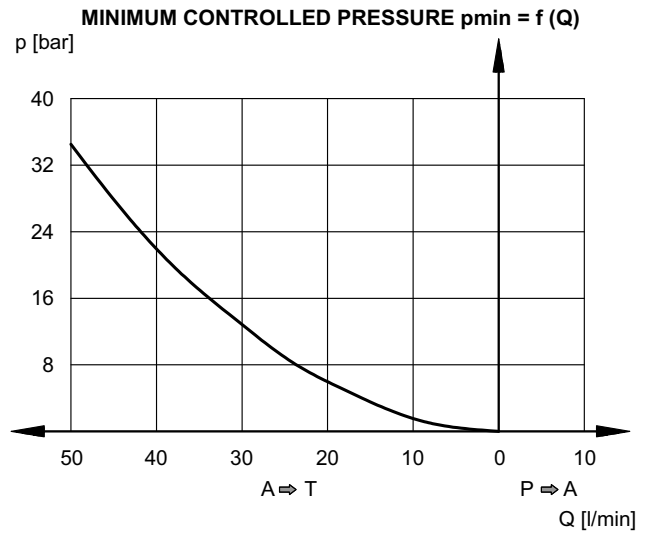
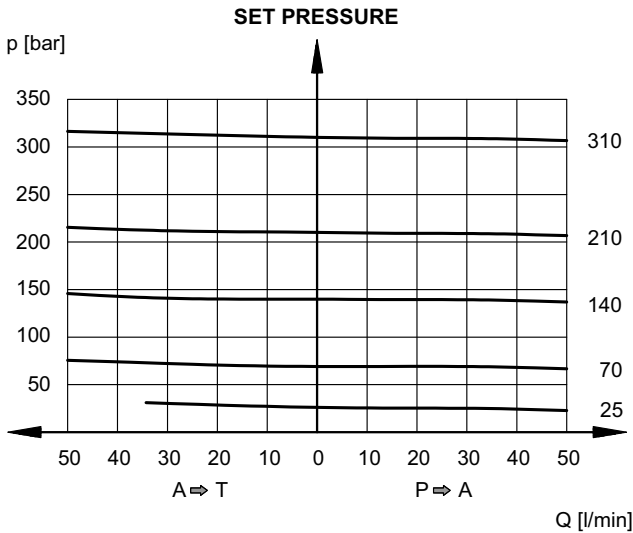

3 - HYDRAULIC FLUIDS

Use mineral oil-based hydraulic fluids HL or HM type, according to ISO 6743-4. For these fluids, use NBR seals (code N). For fluids HFDR type (phosphate esters) use FPM seals (code V). For the use of other fluid types such as HFA, HFB, HFC, please consult our technical department. Using fluids at temperatures higher than 80 °C causes a faster degradation of the fluid and of the seals characteristics. The fluid must be preserved in its physical and chemical characteristics.

4 - ELECTRICAL CHARACTERISTICS

Proportional solenoid

The proportional solenoid comprises two parts: tube and coil.

The tube, screwed to the valve body, contains the armature which is designed to maintain friction to a minimum thereby reducing hysteresis.

The coil is mounted on the tube secured by means of a lock nut and can be rotated through 360° depending on installation clearances.

NOMINAL VOLTAGE	V DC	12	24
RESISTANCE (at 20°C)	Ω	3.66	17.6
MAXIMUM CURRENT	A	1.88	0.86
DUTY CYCLE	100%		
ELECTROMAGNETIC COMPATIBILITY (EMC)	According to 2014/30/EU		
PROTECTION FROM: Atmospheric agents (EN 60529)	IP 65		
CLASS OF PROTECTION: Coil insulation (VDE 0580) Impregnation	class H class F		

5 - STEP RESPONSE

(obtained with mineral oil with viscosity of 36 cSt at 50°C)

Step response is the time taken for the valve to reach 90% of the set pressure value following a step change of reference signal.

REFERENCE SIGNAL STEP	0 → 100%	100 → 0%
Step response [ms]	90	90

6 - INSTALLATION

We recommend to install the PZE3 valve either in horizontal position, or vertical position with the solenoid downward. If the valve is installed in vertical position and with the solenoid upward, you must consider possible variations of the minimum controlled pressure, if compared to what shown in paragraph 2.

Ensure that there is no air in the hydraulic circuit. In particular applications, it can be necessary to vent the air entrapped in the solenoid tube, by using the apposite drain screw in the solenoid tube. Ensure that the solenoid tube is always filled with oil. At the end of the operation, make sure of having screwed correctly the drain screw.

Connect the valve T port directly to the tank. **Add any backpressure value detected in the T line to the controlled pressure value. Maximum admissible backpressure in the T line, under operational conditions, is 2 bar.**

Valves are fixed by means of screws or tie rods on a flat surface with planarity and roughness equal to or better than those shown in the relative symbol. If minimum values are not observed, fluid can easily leaks between valve and support surface.

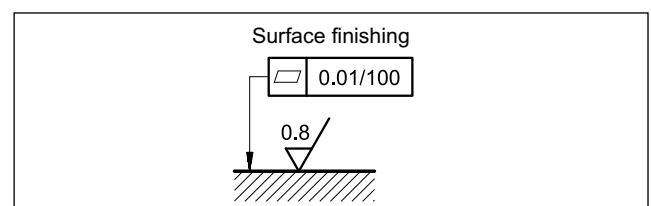

7 - OVERALL AND MOUNTING DIMENSIONS

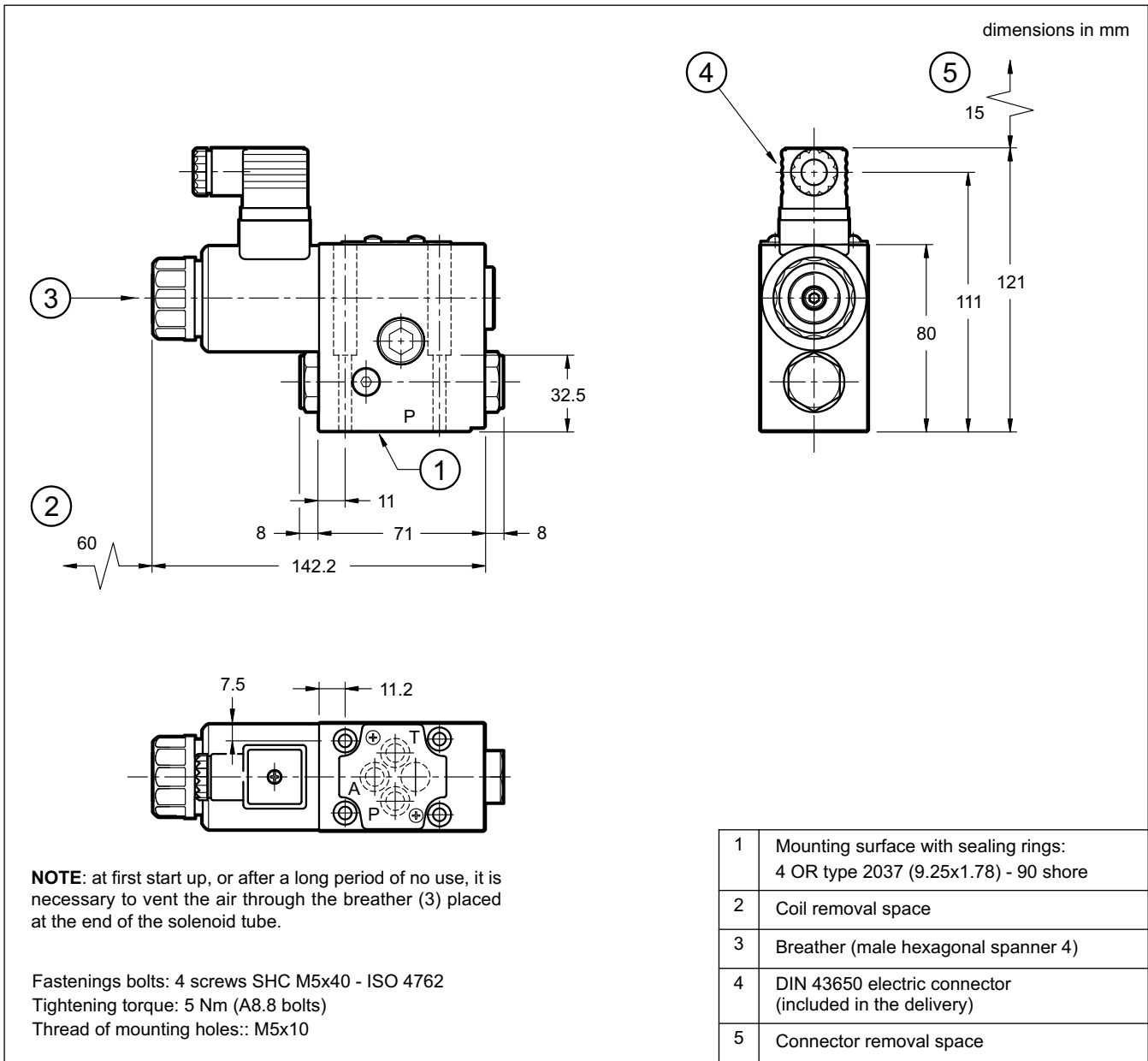

8 - ELECTRONIC CONTROL UNITS

EDC-112	for solenoid 24V DC	plug version	see cat. 89 120
EDC-142	for solenoid 12V DC		
EDM-M112	for solenoid 24V DC	DIN EN 50022 rail mounting	see cat. 89 250
EDM-M142	for solenoid 12V DC		

9 - SUBPLATES

(see catalogue 51 000)

PMMD-AI3G with ports on rear
PMMD-AL3G with side ports
Ports dimensions P, T, A and B: 3/8" BSP thread