



# EWM-S-DAD

## CARD FOR POSITIONING AND VELOCITY STROKE CONTROL WITH PROFIBUS COMMUNICATION INTERFACE

### SERIES 10

**RAIL MOUNTING TYPE:  
DIN EN 50022**

#### OPERATING PRINCIPLE

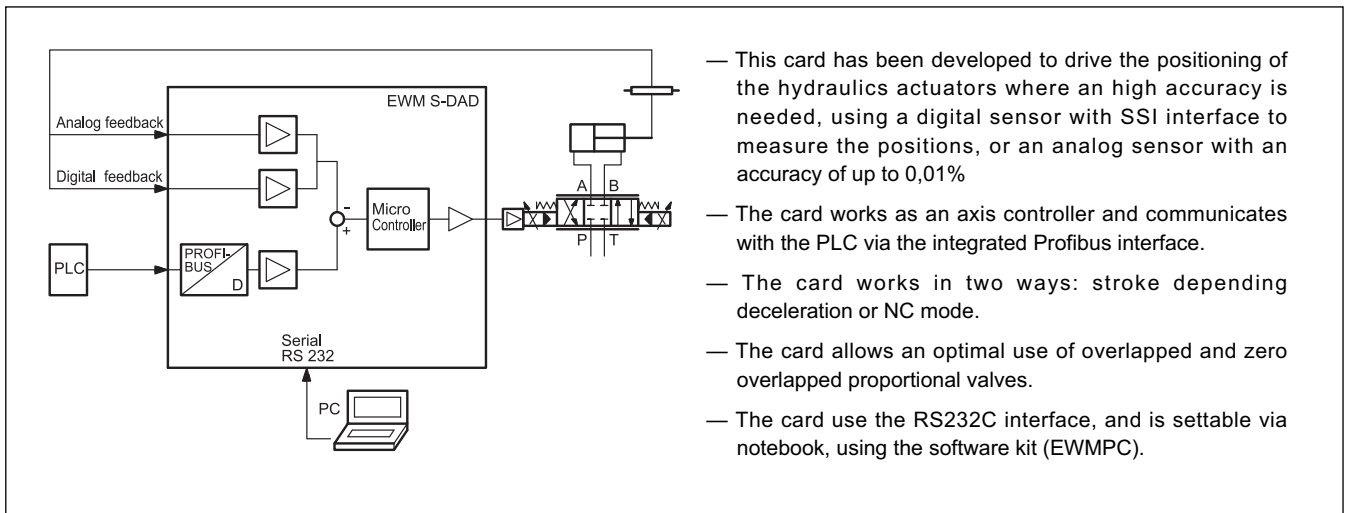

#### TECHNICAL CHARACTERISTICS

Power supply	V DC	12 ÷ 30 ripple included - external fuse 1,0 A
Current consumption	mA	100+ sensor power consumption
Command value		via Profibus DP - ID number 1810h
Feedback value: - digital - analogue	SSI V mA	digital sensor with any interface SSI 0 ÷ 10 (R <sub>f</sub> = 25 kΩ) 4 ÷ 20 (R <sub>f</sub> = 250 Ω)
Position accuracy: - digital - analogue	%	± 2 bits of sensor resolution 0.01
Output value: - E0 version - E1 version	V mA	±10 (max load 5 mA) 4 ÷ 20 (max load 390 Ω)
Interface		RS 232 C
Electromagnetic compatibility (EMC): according to 2004/108/CE standards		Emissions EN 61000-6-3 Immunity EN 61000-6-2
Housing material		thermoplastic polyamide PA6.6 combustibility class V0 (UL94)
Housing dimensions	mm	120 (d) x 99(h) x 46(w)
Connector		4x4 poles screw terminals - PE direct via DIN rail
Operating temperature range	°C	-20 / +60
Protection degree		IP 20

## 1 - IDENTIFICATION CODE

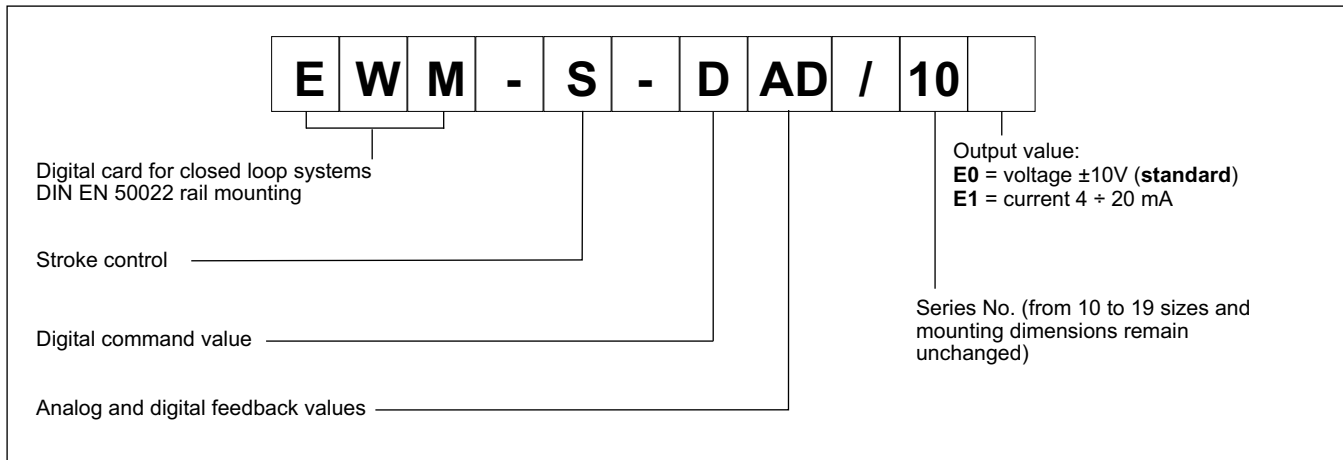

The card EWM-S-DAD is an evolution of an analog model (EWM-S-AD). The customer can choose between two sensor types: analog or digital and the communication with the PLC is via Profibus DP.

With only a few parameters the controller can be optimized and the movement profile is preset via Profibus (position and velocity).

Sample time is 1 ms.

Here below an example of profile with a switch speed:

- the target position is command value 2 (P2) combined with velocity 2 (V2).
- the switch over position is command value 1 (P1), combined with velocity 1 (V1).

Switching over position from a high to a lower speed is calculated by the deceleration function and V2.

Switching over from a low to a high velocity is carried out at the position (P1) via the acceleration ramp; see below.

- If the positioning command value 2 (P2) is between the actual and the position command value 1 (P1), to position 2 (P2) can only be driven with speed 1 (V1).

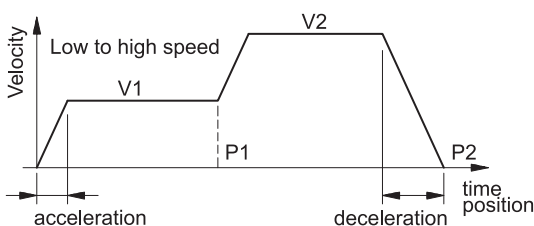
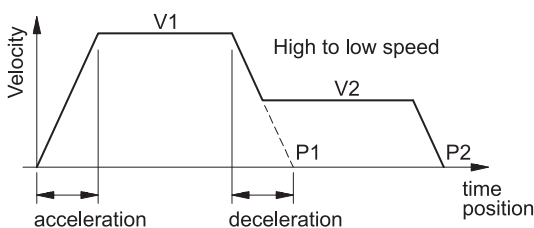

## 2 - FUNCTIONAL SPECIFICATIONS

### 2.1 - Power supply

This card is designed for 12 to 30 VDC (typical 24 V) of a power supply. This power supply must correspond to the actual EMC standards. All inductivities at the same power supply (relays, valves) must be provided with an over voltage protection (varistors,

free-wheel diodes). It is recommended to use a regulated power supply (linear or switching mode) for the card supply and the sensors.

### 2.2 - Electrical protections

All inputs and outputs are protected with suppressor diodes and RC-filters against transient overshoots.

### 2.3 - Digital Input (ENABLE)

The card accepts digital input. The digital input must have a voltage from 12 to 24 V; Low level:  $< 2V$ , high level  $> 10V$  with current  $< 50mA$ . See the block diagram at paragraph 8 for the electric connections.

### 2.4 - Command value

The card accepts the input via Profibus, ID number 1810h (see paragraph 4).

### 2.5 - Input feedback values

The card accepts analogue or digital feedback input. The digital sensor parameters are settable via software (see parameters table). with analogue feedback the signal must can be  $0 \div 10$  V ( $R_i = 25$  k $\Omega$ ) or  $4 \div 20$  mA ( $R_i = 250\Omega$ ) Analogue sensor max resolution is 0.001 mm.

### 2.6 - Output values

E0 version: output voltage  $0 \pm 10$  V (standard).

E1 version: output current  $4 \div 20$  mA with max load 390 $\Omega$ .

### 2.7 - Digital Output

Two digital output are available, INPOS and READY, that are displayed via LEDs on the front panel.

Low level  $< 2V$  High Level  $> 10$  V Max 50 mA with load 200 $\Omega$ .

## 3 - LED FUNCTIONS

There are three leds on the card: one on the profibus module, that shows the online status of Profibus connection, and two on the other module:

GREEN: Shows if the card is ready.

ON - The card is supplied

OFF - No power supply

FLASHING - Failure detected (internal or  $4 \dots 20$  mA).

Only if SENS = ON

YELLOW: Is the signal of the control error monitoring.

ON - No control error



### 4 - ADJUSTMENTS

On the EWM cards, the adjustment setting is possible only via software.

Connecting the card to the PC, the software automatically recognises the card model and shows a table with all the available

commands, with their parameters, the default settings, the measuring unit and an explanation of the commands and its uses. The parameters change depending on the card model.

#### EXAMPLE OF PARAMETERS TABLE

Command	Parameters	Defaults	Units	Group	Description
<b>LG</b> x	x= DE GB	GB	-	STD	Changing language help texts.
<b>MODE</b> x	x=STD EXP	STD	-	STD	Mode parameter.
<b>TS</b> x	x= 5..30	10	0,1 ms	EXP	Changing the controller sample time.
<b>STROKE</b> x	x= 10..10000	100	mm	STD	Working stroke or the sensor.
<b>VS</b> x	x= EXT INT	INT	-	STD	Switch over between internal and external velocity preset.
<b>VELO</b> x	x= 1..10000	10000	0,01%	STD	Here the max velocity can be limited internally. The limitation function corresponds to the external velocity preset if VS was parameterized with EXT
<b>VRAMP</b> x	x= 10..5000	200	ms	VS=EXT	Ramp time for velocity input.
<b>VMODE</b> x	x= SDD NC	SDD	-	EXP	Control structure for positioning process. SDD: stroke-dependent deceleration is activated. From the set deceleration point the drive then switches to control mode and moves accurately to the desired position. NC: In this mode a position profile is generated internally. The system always works under control and uses the following error to follow the position profile.
<b>VMAX</b> x	x= 1..3000	50	mm/s	VMODE=NC	Max velocity in NC mode.
<b>EOUT</b> x	x= -10000..10000	0	0,01%	EXP	When an input error occurs the adjusted value of 'EOUT' will be displayed at the output pin 15/16. A value less than 100 deactivates this function.
<b>POL</b> x	x= - +	+	-	STD	For changing the output polarity. All <b>A</b> and <b>B</b> adjustments depend on the output polarity. The right polarity should be defined first.
<b>SENS</b> x	x= ON OFF AUTO	AUTO	-	STD	Activation of the sensor and internal failure monitoring.
<b>AIN:W</b> <b>AIN:X</b>	A= -10000..10000 B= -10000..10000 C= -500..10000 X= V C	A: 1000 B: 1000 C: 0 X: V	-	STD	Analogue output selection. <b>W</b> and <b>X</b> for the inputs and <b>V</b> = voltage, <b>C</b> = current. With the parameters <b>a</b> , <b>b</b> and <b>c</b> the inputs can be scaled (output = a / b * (input - c)). Because of the programming of the x-value (x = C) the corresponding input will be switched over to current automatically.
<b>A:A</b> x <b>A:B</b> x	x= 1..5000 x= 1..5000	100 100	ms ms	STD	Acceleration time depending on direction. <b>A</b> indicates analogue output 15 and <b>B</b> indicates analogue output 16. Normally <b>A</b> = flow P-A, B-T and <b>B</b> = flow P-B, A-T.
<b>D:A</b> x <b>D:B</b> x <b>D:S</b> x	x= 1..10000 x= 1..10000 x= 1..10000	25 25 10	mm mm mm	VMODE=SDD	Deceleration stroke dependent from direction. The loop gain is calculated by the deceleration stroke. The shorter the higher. In case of instabilities longer deceleration stroke should be set Loop Gain = STROKE / D:A o STROKE / D:B.
<b>V0:A</b> x <b>V0:B</b> x	x= 1..200 x= 1..200	10 10	1/s 1/s	VMODE=NC	Loop Gain for NC mode: D:A = VMAX / V0:A e D:B = VMAX / V0:B Loop Gain = STROKE / D:A o STROKE / D:B.
<b>CTRL</b> x	x= lin sqrt1 sqrt2	sqrt1	-	STD	Selection of the control function: (see <b>NOTE</b> ) <b>lin</b> = standard linear P-control, <b>sqrt1</b> = progressive time optimized deceleration curve. <b>sqrt2</b> = sqrt1 with a higher gain in position.
<b>HAND:A</b> x <b>HAND:B</b> x	x= -10000..10000 x= -10000..10000	3330 -3330	0,01% 0,01%	STD	Hand speed (in manual mode) For the corresponding switch input the direction can be defined by the sign.
<b>MIN:A</b> x <b>MIN:B</b> x	x= 0..6000 x= 0..6000	0 0	0,01% 0,01%	STD	Zero point setting /following error compensation.
<b>MAX:A</b> x <b>MAX:B</b> x	x= 3000..10000 x= 3000..10000	10000 10000	0,01% 0,01%	STD	Maximum output signal limitation.
<b>TRIGGER</b> x	x= 0..4000	200	0,01%	STD	Trigger threshold for activating the following error compensation (MIN).
<b>OFFSET</b> x	x= -4000..4000	0	0,01%	STD	Offset value added to the output signal. (setpoint - actual value + offset).
<b>INPOS</b> x	x= 2..200000	200	µm	STD	Range for InPos signal. (See <b>NOTE</b> )



<b>INPX</b>	<b>x</b>	x= ANA SSI	ANA	-	STD	Sensor input changeover.
<b>SSI:OFFSET</b>	<b>x</b>	x= -1000000... 1000000	0	μm	INPX=SSI	Position Offset.
<b>SSI:POL</b>	<b>x</b>	x= + -	+	-	INPX=SSI	Sensor polarity. To reverse the sensor working direction its polarity can be changed with this command.
<b>SSI:RES</b>	<b>x</b>	x= 100... 10000	500	10 nm	INPX=SSI	Resolution of the sensor. The highest resolution (1000) corresponds to 1 μm. This sensor resolution is always used for the input data via Profibus and is needed for the internal calculations. (see <b>NOTE</b> )
<b>SSI:BITS</b>	<b>x</b>	x= 8... 31	24	bits	INPX=SSI	Number of bits transmitted.
<b>SSI:CODE</b>	<b>x</b>	x= GREY BIN	GREY	-	INPX=SSI	Transmission coding.

**NOTE about the CTRL command:** This command controls the braking characteristic of the hydraulic axis. With positive overlapped proportional valves one of both SQRT braking characteristics should be used because of the linearization of the non-linear flow curve typical of these valves. If zero overlapped proportional valves (control valves) are used, you can choose between LIN and SQRT1 according to the application. The progressive gain characteristic of SQRT1 has the better positioning accuracy.

According to the application there is maybe a longer braking distance, so that the total stroke time will be longer.

LIN: Linear braking characteristics (control gain corresponds to:  $10000 / d:i$ ).

SQRT\*: Root function for the calculation for the braking curve.

SQRT1: with small control error. Control gain corresponds to  $30000 / d:i$  ;

SQRT2: control gain corresponds to  $50000 / d:i$

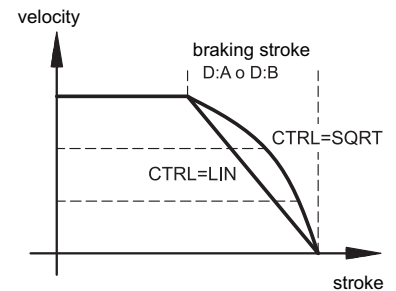

**NOTE about the INPOS command:** The INPOS command defines the window in relation to the stroke where the INPOS message is indicated. The monitored area is derived from the setpoint value minus the half "Inpos" value until setpoint value plus the half "Inpos" value. The positioning process is not influenced by this message. The controller remains active. In NC-mode this message has to be interpreted alternatively as following error.

**NOTE about the SSIRES command:** the standard of measurement is defined as increment/mm (inkr/mm). The maximum available resolution is equal to 1 μm that corresponds to a value 1000.

Example: A sensor with resolution 5μm has a resolution (0.005 mm) 5 times lower than the maximum set.

The SSIRES value is calculated as follows:  $1000$  (full scale ink) /  $n$  (sensor resolution in μm) =  $1000 / 5 = 200$



## 5 - PROFIBUS COMMUNICATION

The module supports all baud rates from 9,6 kbit/s up to 12000 kbit/s with auto detection of the baud rate. The functionality is defined in IEC 61158. The Profibus address can be programmed with the EWMP/10 software or online via the Profibus. A diagnostic LED indicates the online status.

### 5.1 - Data Sent

The card is set as follows:

Byte	Function	Comment
0	control word Hi	
1	control word Lo	actual not used
2	command position 1 Hi	
3	command position 1	
4	command position 1	
5	command position 1 Lo	
6	velocity 1 Hi	
7	velocity 1 Lo	active, if a second velocity is programmed (Bytes 13 and 14)
8	command position 2 Hi	
9	command position 2	
10	command position 2	
11	command position 2 Lo	
12	velocity 2 Hi	reserved
13	velocity 2 Lo	
14	-	
15	-	

### 5.1.2 - Control words

The control words contain the following informations:

- ENABLE:** Must be activated in addition to the hardware signal.
- START:** In case of increasing edge the current command position is taken over, in case of deactivated START the system about a brake ramp is stopped.
- HAND-:** Hand mode (START = OFF), driving with the velocity programmed with the HAND:B parameter according to the hydraulic symbol of the valve. After deactivation the actual value is taken over as command position.
- HAND+:** Hand mode (START = OFF), driving with the velocity programmed with the HAND:A parameter according to the hydraulic symbol of the valve. After deactivation the actual value is taken over as command position.

Byte 0 - control word Hi		
bit	Function	
0		
1		
2		
3		
4	Hand-	1 = active
5	Hand+	1 = active
6	Start	1 = active
7	Enable (with hardware enable)	

The ENABLE bit is combined with the external enable input; that means that both signals must exist, in order to enable the axes..

### 5.1.3 - Position setpoint description

Command position: according to the sensor resolution.

Byte 2 to 5 - command position 1		
bit	Function defined by the sensor resolution	
from 0 to 7	Command position Lo byte	Byte 5
from 8 to 15	Command position	Byte 4
from 16 to 23	Command position	Byte 3
from 24 to 31	Command position Hi byte	Byte 2

Byte 8 to 11 - command position 2		
bit	Function defined by the sensor resolution	
from 0 to 7	Command position Lo byte	Byte 11
from 8 to 15	Command position	Byte 10
from 16 to 23	Command position	Byte 9
from 24 to 31	Command position Hi byte	Byte 8

Example of calculation of position control for SSI sensor resolution = 5 µm and 100% stroke = 300 mm.

Position setpoint = 150 mm (= 50% stroke)

STROKE • SSIREs = 100% stroke (dec)

300 • 200 = 60.000 (dec) → EA60 (hex)

50% di 60.000 = 30.000 (dec) → 7530 (hex)

Example of calculation of position control for ANA sensor with 100% stroke = 300 mm. With analog sensors SSIREs value is preset and unchangeable.

Position setpoint = 150 mm (= 50% stroke)

STROKE • SSIREs = 100% stroke (dec)

300 • 1000 = 300.000 (dec) → 493E0 (hex)

50% di 300.000 = 150.000 (dec) → 249F0 (hex)

Position setpoint to be sent

with decimal value 150,000 :

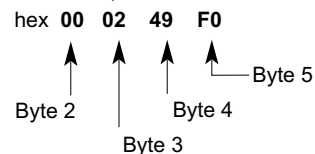

### 10.1.4 - Speed setpoint description

Command velocity: 0x3fff corresponds to 100 %.

Byte 6 and 7 - command velocity 1		
bit	Function max value 0x3FFF	
from 0 to 7	velocity Lo byte	Byte 7
from 8 to 15	velocity Hi byte	Byte 6

Byte 12 and 13 - command velocity 2		
bit	Function max value 0x3FFF	
from 0 to 7	velocity Lo byte	Byte 13
from 8 to 15	velocity Hi byte	Byte 12



## 5.2 - Updating data

The card send back to the bus-card a totally of 24 bytes of data.

Byte	Function	Comment
0	status word Hi	
1	status word Lo	not used
2	actual position Hi	
3	actual position	
4	actual position	
5	actual position Lo	
6	internal command position Hi	
7	internal command position	
8	internal command position	
9	internal command position Hi	
10	Control deviation Hi	in resolution of the positioning sensor
11	Control deviation	
12	Control deviation	
13	Control deviation Lo	
14		
15		

### 5.2.1 - Status word description

The status words are:

READY: System is ready.

INPOS: Depending on the mode set, can transmit a target reached information or, in NC mode, the following error control information.

Byte 1 - status word Hi		
bit	Function	
0		
1		
2		
3		
4		
5		
6	INPOS	1 = actual value in position window
7	READY	1 = ready to operate

### 5.2.2 - Positioning description

Bytes 2 to 5 - Actual position		
byte	Function defined by the sensor resolution	
from 0 to 7	Actual position Lo-Byte	Byte 5
from 8 to 15	Actual position	Byte 4
from 16 to 23	Actual position	Byte 3
from 24 to 31	Actual position Hi-Byte	Byte 2

Current command position: is interpreted according to mode differently.

SDD mode : target command position

NC-mode : (V<sub>MODE</sub> = ON) calculated command position of the generator.

Actual position: according to the sensor resolution.

The stroke of the cylinder is obtained by applying the following formula:

received data / SSIRES = stroke

hex 00 04 90 F3 = dec 299251

↑     ↑     ↑     ↑  
 Byte 2   Byte 3   Byte 4   Byte 5

so, with SSIRES = 1000

299251 / 1000 = 299,251 (millimetres)

Bytes 6 to 9 - Internal command position		
byte	Function defined by the sensor resolution	
from 0 to 7	Command position Lo-Byte	Byte 9
from 8 to 15	Command position	Byte 8
from 16 to 23	Command position	Byte 7
from 24 to 31	Command position Hi-Byte	Byte 6

Bytes 10 to 13 - Control deviation		
byte	Function defined by the sensor resolution	
from 0 to 7	Control deviation Lo-Byte	Byte 13
from 8 to 15	Control deviation	Byte 12
from 16 to 23	Control deviation	Byte 11
from 24 to 31	Control deviation Hi-Byte	Byte 10

## 6 - INSTALLATION

The card is designed for rail mounting type DIN EN 50022.

The wiring connections are on the terminal strip located on the bottom of the electronic control unit. It is recommended to use cable sections of 0.75 mm<sup>2</sup>, up to 20 m length and of 1.00 mm<sup>2</sup> up to 40m length, for power supply and solenoid connections. For other connections it is recommended to use cables with a screened sheath connected to earth only on the card side.

**NOTE:** To observe EMC requirements it is important that the control unit electrical connection is in strict compliance with the wiring diagram. As a general rule, the valve and the electronic unit connection wires must be kept as far as possible from interference sources (e.g. power wires, electric motors, inverters and electrical switches).

In environments that are critical from the electromagnetic interference point of view, a complete protection of the connection wires can be requested.

A typical screened Profibus plug (D-Sub 9pol with switchable termination) is mandatory. Also the Profibus cable must be screened.

Every Profibus segment must be provided with an active bus termination at the beginning and at the end. The termination is already integrated in all common Profibus plugs and can be activated by DIL switches.

In environments that are critical from the electromagnetic interference point of view, a complete protection of the connection wires can be requested.

## 7 - SOFTWARE KIT EWMPC/10 (code 3898401001)

The software kit comprising a USB cable (1.8 mt length) to connect the card to a PC or notebook and the software.

During the identification all information are read out of the module and the table input will be automatically generated.

Some functions like baud rate setting, remote control mode, saving of process data for later evaluation are used to speed up the installation procedure.

The software is compliant with Microsoft XP® and Windows7 operating systems.

## 8 - WIRING DIAGRAM

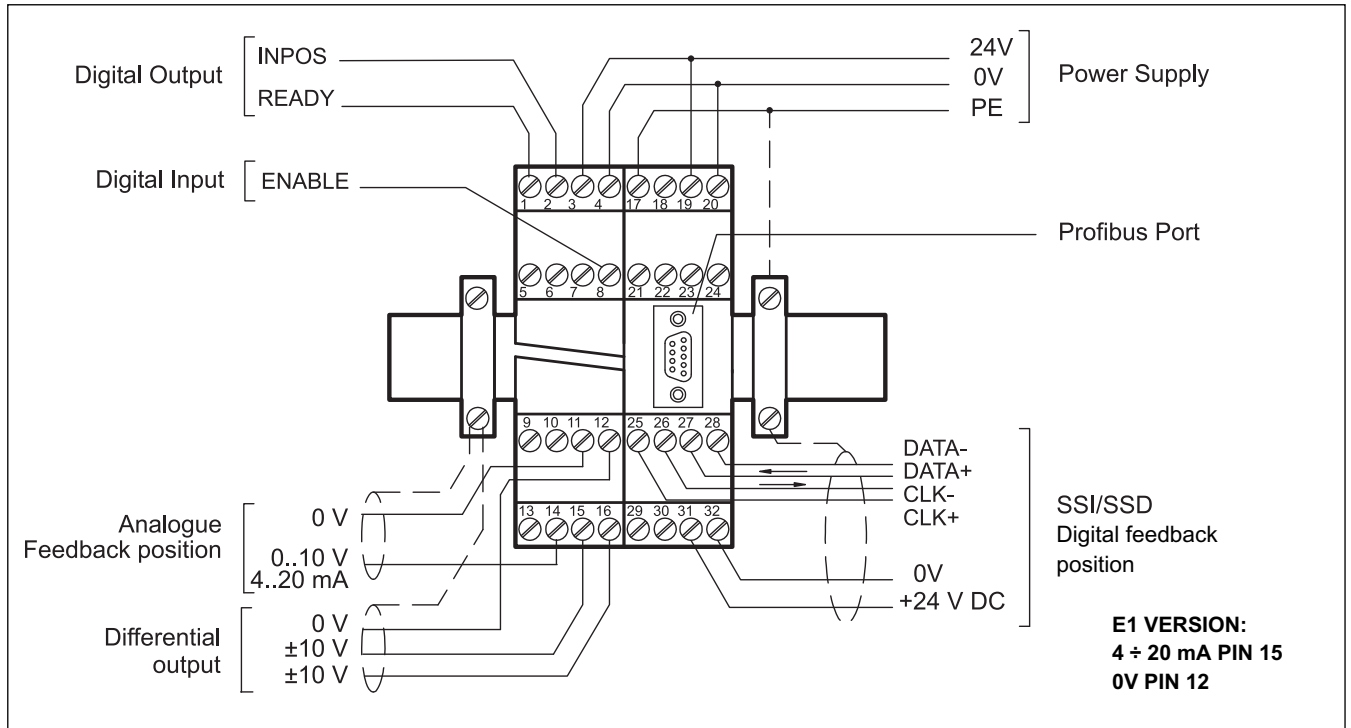

### DIGITAL INPUT AND OUTPUT

- PIN 1** READY output.  
 General operability, ENABLE is active and there is no sensor error (by use of 4+20 mA sensors). This output corresponds with the green LED.
- PIN 2** INPOS output.  
 Monitoring of the control error (INPOS). Depending on the INPOS command, the status output will be deactivated, if the position difference is greater then the adjusted window.  
 The output is only active if START = ON.
- PIN 8** ENABLE input:  
 This digital input signal initializes the application. The analogue output is active and the READY signal indicates that all components are working correctly. Target position is set to actual position and the drive is closed loop controlled.

### ANALOGUE INPUT AND OUTPUT

- PIN 14** Analogue feedback value (XL), range 0 ÷ 100% corresponds to 0 ÷ 10V or 4 ÷ 20 mA
- PIN 15/16** Differential output (U)  
 ±100% corresponds to ± 10V differential voltage, optionally (E1 version) current output ±100% corresponds to 4 ÷ 20 mA (PIN 15 to PIN 12)

### PROFIBUS PORT WIRING AND LINKING CONFIGURATION

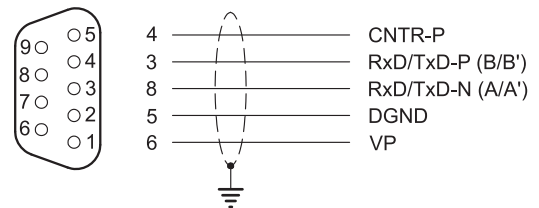

pin	Signal name	Function
1-2-7-9	not used	-
3	RxD/TxD-P (B-Line)	Receive/Send P data
4	CNTR-P/RTS	Request to Send
5	DGND	Data ground
6	VP	+5 V DC for external bus termination
8	RxD/TxD-N (A-Line)	Receive/Send N data



# EWM-S-DAD

## SERIES 10

### 9 - CARD BLOCK DIAGRAM

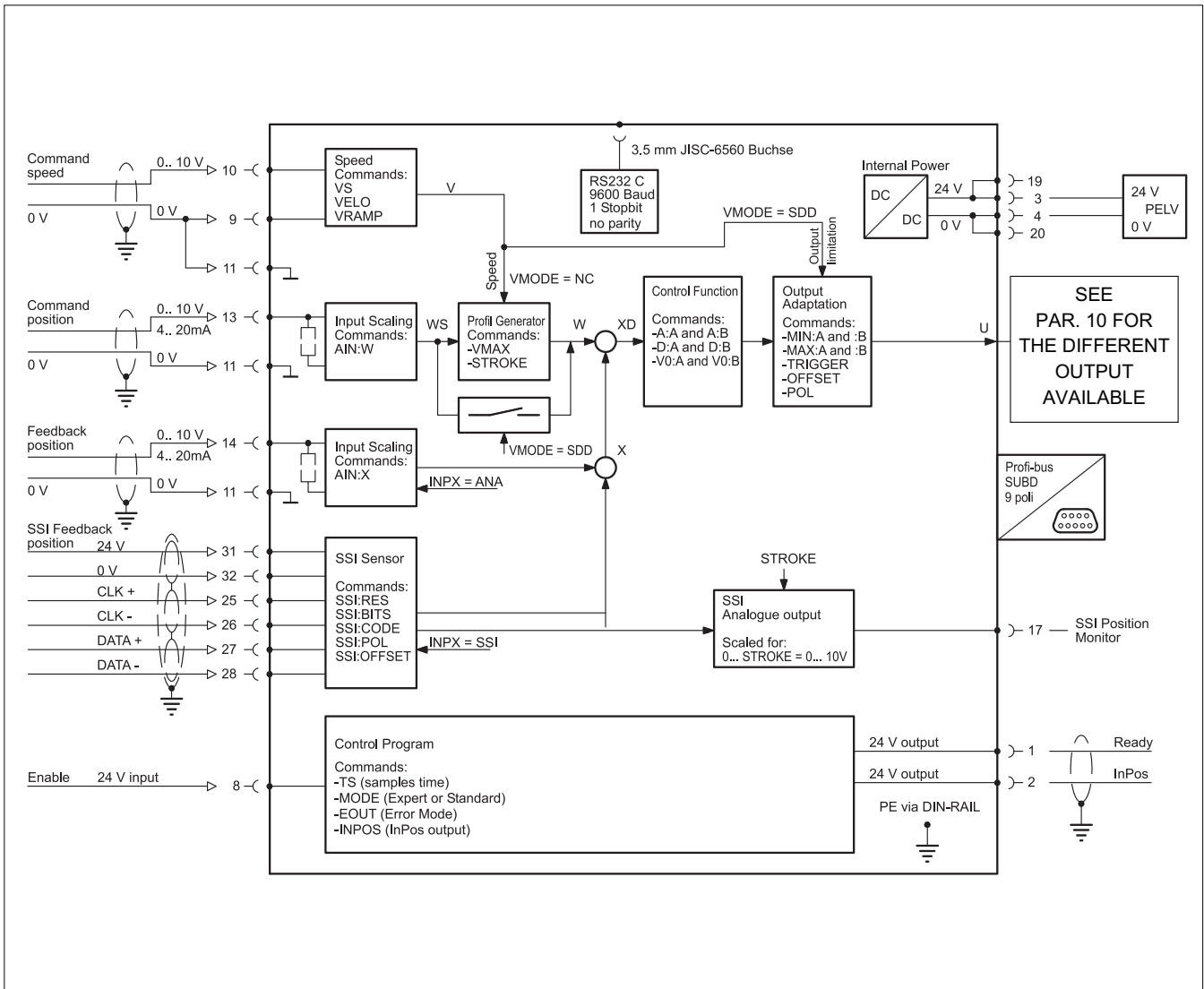

### 10 - OUTPUT SIGNALS AVAILABLE FOT DIFFERENT VERSIONS

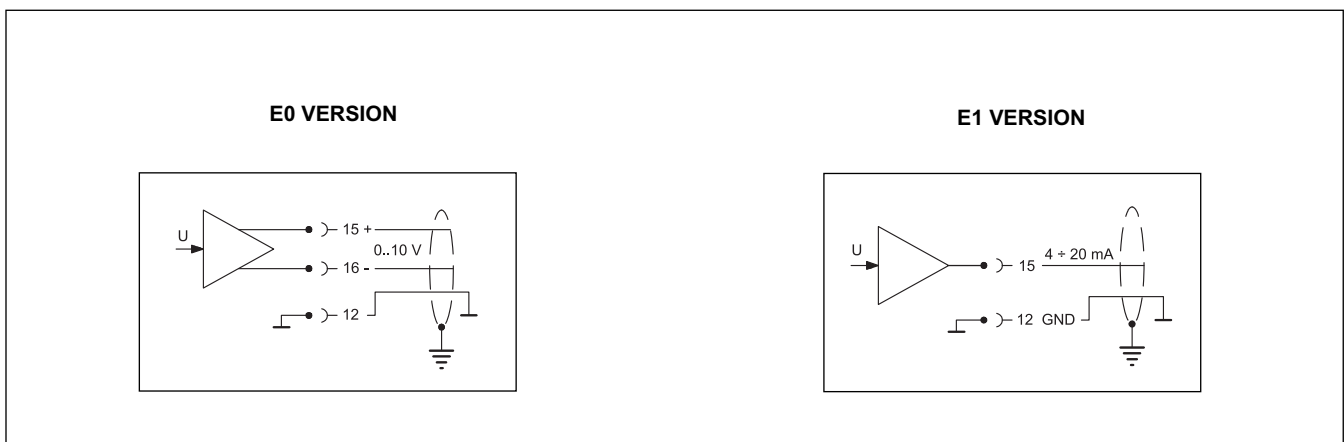



## 10 - OVERALL AND MOUNTING DIMENSIONS

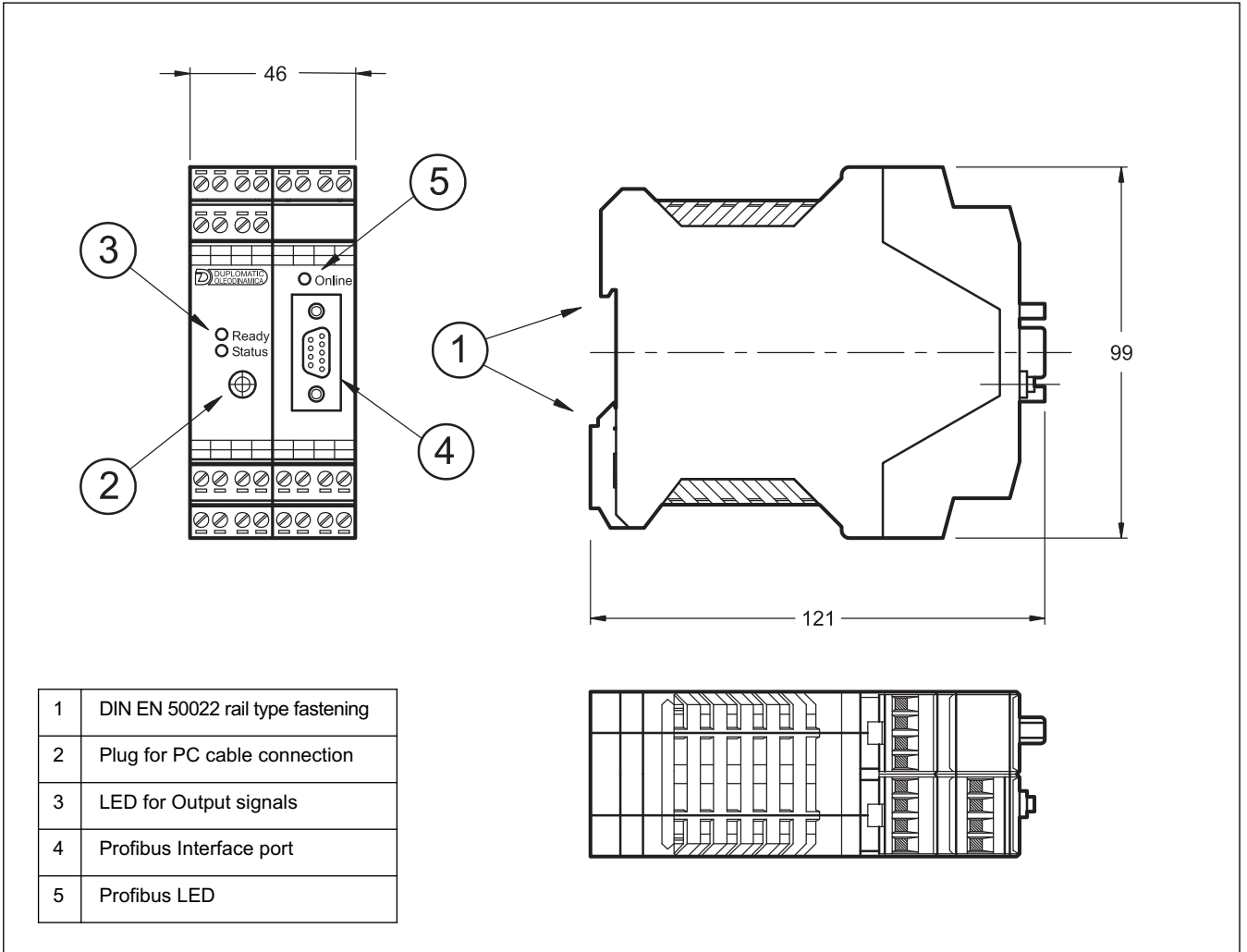



# EWM-S-DAD

SERIES 10



**DIPLOMATIC OLEODINAMICA S.p.A.**  
20015 PARABIAGO (MI) • Via M. Re Depaolini 24  
Tel. +39 0331.895.111  
Fax +39 0331.895.339  
[www.diplomatic.com](http://www.diplomatic.com) • e-mail: [sales.exp@diplomatic.com](mailto:sales.exp@diplomatic.com)

